

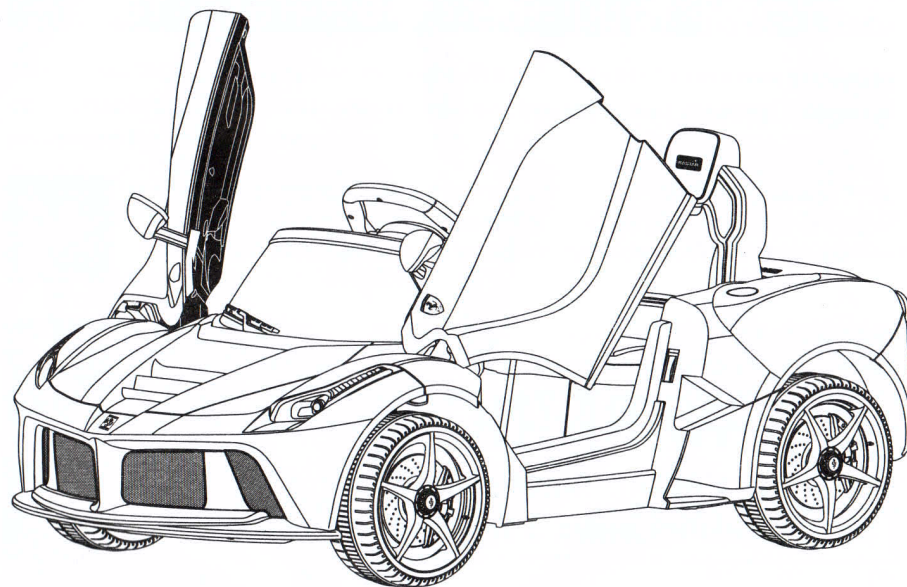

RASTAR GROUP

LaFerrari

Ride-on Instruction



The packing has to be kept since it contains important information.



WARNING:

CHOKING HAZARD-Small parts.
Not for children under 3 years.

Hereby, [XINGHUI BABY SUPPLIES CO., LTD.], declares that this [LaFerrari] is in compliance with the essential requirements and other relevant provisions of Directive 1995/5/EC.

CONTENTS

ABOUT "RASTAR BABY" PRODUCT	01
SPECIFICATION	02
PARTS	02
ASSEMBLY	04
TRANSMITTER BATTERY REPLACEMENT	06
NORMAL OPERATION	07
STORAGE BATTERY MAINTENANCE	07
OVERCURRENT PROTECTOR	08
OPERATING FUNCTION	08
WARNING	10
CARE AND MAINTENANCE	11
MALFUNCTION SHOOTING GUIDE	11
RIDE-ON ELECTRICAL ILLUSTRATION	12
MAINTENANCE	13

ABOUT "RASTAR BABY" PRODUCT

Thank you for purchasing our products. We have devoted ourselves to creating comfortable and safe electronic remote control toys, and creating a colorful childhood for your children.



It is very important to read this instruction carefully before usage. This instruction not only specifies assembly process and proper application method, but also help you to avoid injury or damaging the product in case of incorrect operation.



XINGHUI BABY SUPPLIES CO., LTD. reserves the right of the final explanation to all the pictures and descriptions contained in this manual. The manual is subject to change without separate notice. Please contact your local distributor or directly consult us if you have any questions.



This product can be operated in Battery operated/Radio control mode, together with forward, reverse, left, right, and equipped with functions like headlight, built-in music playing and AUX input.

NO.	Style	Remark
82700	Radio control with painting	Both Radio control and Battery operated

SPECIFICATION

Size	(121.9x60.4x51.3)cm
For child	37months old - 96months old
Max.weight loaded	25kg
Net Weight	18.08kg
Power	Rechargeable
Speed	(3-4)km/h
Battery	6V 7Ah lead-acid 6V 10Ah lead-acid 6V 12Ah lead-acid
Power supply	Input:AC220V 50Hz Output:DC6V 500mA Subject to the nameplate of the charger
Charging period	Charged for (10-15)h/time Can be used more than 60 minutes
Rechargeable times	More than 300
For temperature	(5-35) Celsius degree
Power of Motor	DC6V 25W

PARTS

NO.	Desc.	Qty	NO.	Desc.	Qty
1	Steering Wheel	1	10	Hexnut	1
2	Windshield	1	11	Charger	1
3	Seat	1	12	Transmitter	1
4	Screw	1	13	Lubricant	1
5	Protector	5	14	AUX Input line	1
6	Storage Battery	1	15	Car Body	1
7	Battery Locker	1	16	Wheel	4
8	Battery Cover	1	17	Wheel Core(backup)	2
9	Screw Pin	1	18	Instruction	1

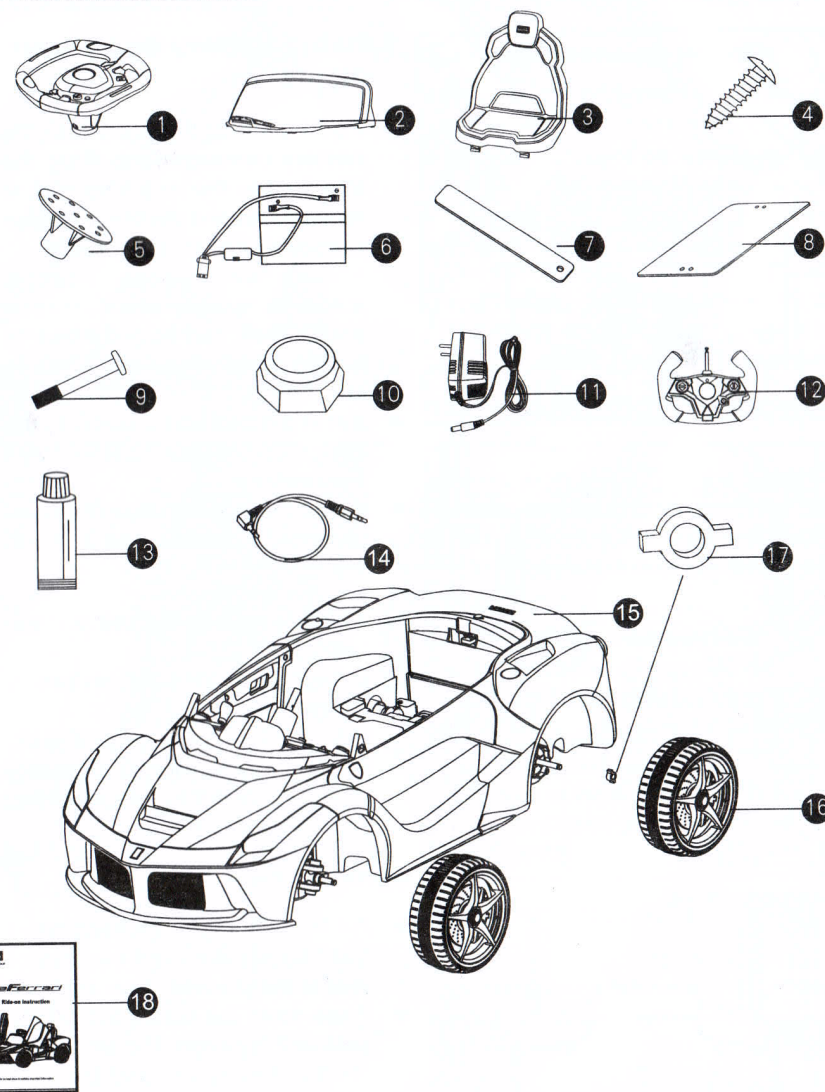

The serial number of all spare parts showed as "(NO.)" in the following descriptions.



If the quantity and shape of some spare parts in this manual are different from that of products you buy, it might be because some parts of the car you buy already have been installed or because we reduce setup steps and quantities of spare parts for making the installing easier. Please check and review.

ASSEMBLY

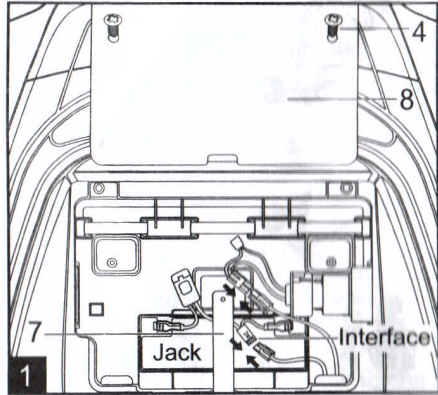

1. Install battery and power supply

- Put the storage battery into the battery compartment. Plug the interface to the jack, connect the red terminal and the black terminal respectively to the anode and cathode of battery. (Notice: make sure they are correctly connected, red to red, black to black, otherwise, it will cause short-circuit.)
- Install the battery locker(7) to the designated position, and fix it with 2 screws(4)
- Install the battery cover(8) to the designated position, and fix it with 2 screws(4)
- ★ Replace or take out the storage battery and power.
Loosen the 2 screws(4) on battery cover(8)
Unplug the interface and jack, loosen the 2 screws(4) on battery locker(7), then the storage battery can be taken out.

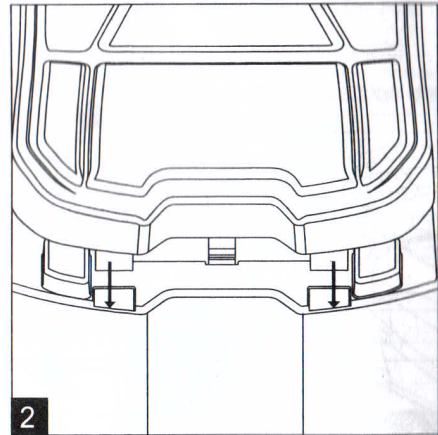

2. Install seat

- Put the seat (3) to the designated position, fix the front buckles of seat to the grooves of car body.
 - Press down the button behind the seat and lay down the seat, then release the button and the seat will be locked. To unlock the seat, press down the button and raise the seat.
- Notice: This seat is equipped with seat belt, which is only a decoration to develop the safety sense of children, it can not provide any substantial protection.

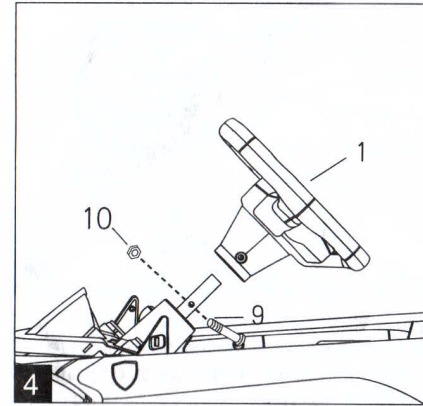
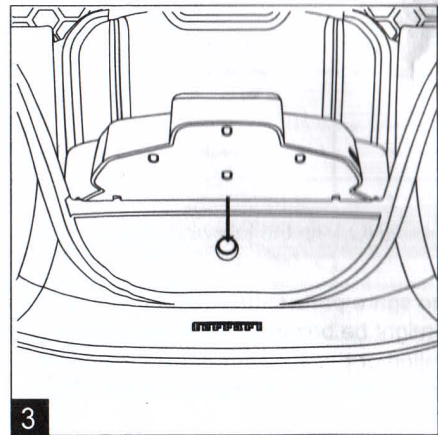

3. Install steering wheel

- Remove the protector (5) at the upside of the axes, which is non-functional but only for protecting use during the transportation. Please dispose properly.
- Please install the steering wheel (1) to the specific place and use Screw (9) and Hexnut (10) to screw it tightly after you make sure the steering wheel is in the right place. Please see picture 4.

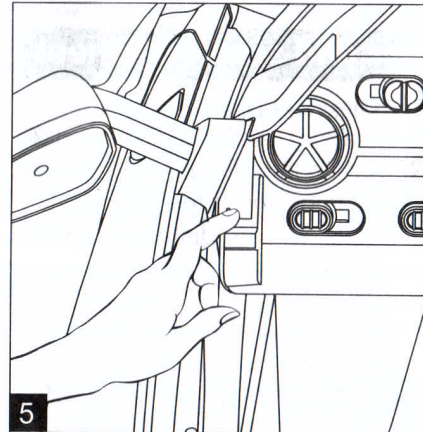

4. Install windshield and wing mirror

- Install windshield(2) to the designated position, and fasten it.
- Push the windshield forward and downward to lock it. And do reversely to uninstall it. See picture 5.

5. Assembly completed 6. Schematic diagram of assembly and disassembly

- Picture 7 is schematic diagram of assembly, disassembly and maintenance. Please pay attention to the sequence of spare parts install and take good care of them after disassembly.

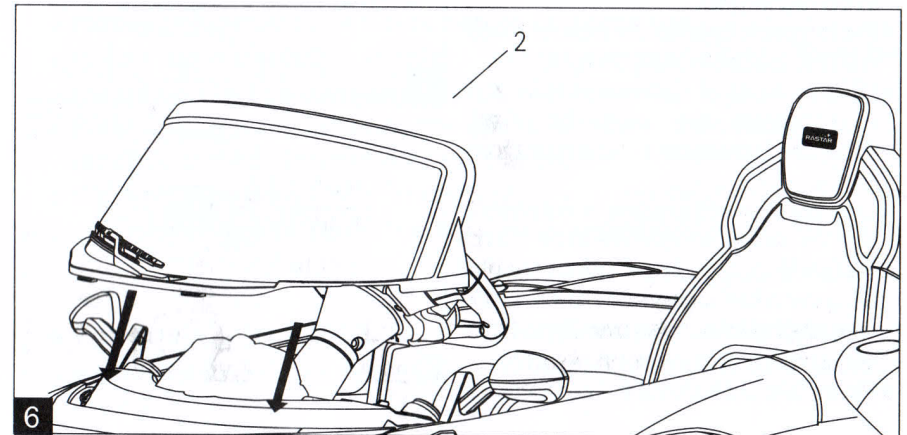

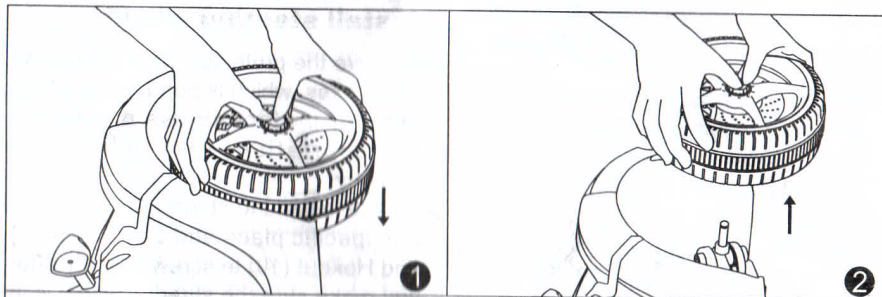

7 Steps of Wheel Installation: Set the wheel into the iron shaft straight until you hear a "click" sound and unable to pull the wheel back. It means the wheels are successfully installed. If you want to dismantle the wheel, pressing the wheel cover to remove the wheel.

Replace battery of transmitter and steering wheel

1. Replace battery of transmitter

- Put the antenna into the controller socket. Open the lid and put the 9V battery according to its polarity, then close the lid.

2. Replace battery of steering wheel

- Please take down the battery cover according to the indicating arrow in the picture.
- Properly put two "AA" batteries into steering wheel and then cover it.

3. Notice while replacing battery

- Non-rechargeable batteries are not to be recharged.
- Rechargeable batteries are to be removed from the toy before being charged.
- Different types of batteries or new and used batteries are not to be mixed. Exhausted batteries are to be removed from the toy.
- Only batteries of the same or equivalent type as recommended are to be used.
- Batteries replaced by children should be under adults' supervision. Please do not swap the batteries' poles over. Short circuit should not occur to the electrical source.
- Please take out batteries in case of leakage

and corrosion if long term storage.

- Please take out batteries when it is power off.
- Remote control is only applicable to adults or under the guidance of adults (a safe distance is 10M).

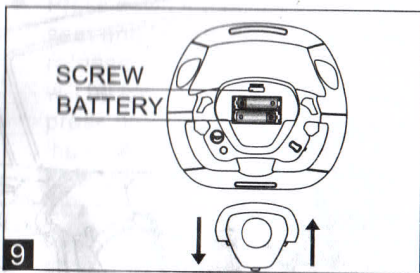
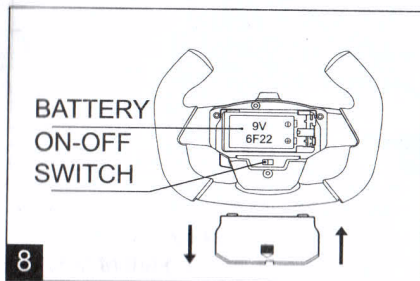

NORMAL OPERATION

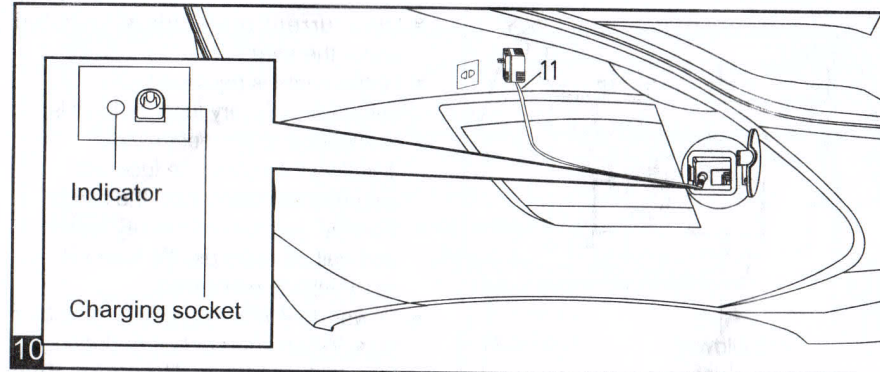

- Charging socket is under the filler cap. Open the filler cap and insert the plug of charger, then connect the charger with power.
- Every one hour's running needs 10 to 15 hours' charging. Every single charging can not over 24 hours.
- Both charger and storage batteries will occur mildly warm during charging.
- Do not use mal-functioned adapter or storage battery unless they are repaired.
- This manual has to be kept since it contains important information.
- Charger and storage batteries are not considered as toys.
- Please make periodical inspection for storage battery, especially for adapter wires and plugs.
- Please turn off the switch when the ride-on is not in use. Please make full charging after long-term suspended.
- ONLY use the charger supplied by Rastar or Rastar Baby.

STORAGE BATTERY MAINTENANCE

- Please charge 20 to 24 hours before first time use.
- Please use the suitable adapter to charge storage battery, otherwise the ride-on will be damaged.
- Please charge the car once the speed is slower than normal, otherwise it will decrease storage battery life.
- Please fully charge the battery before you put your ride-on away, and remember to recharge the battery every 30 days. This will ensure the normal use of the battery, otherwise, the battery can not be charged.
- For safety, please ONLY use the battery supplied by Rastar or Rastar Baby, which has been protected with polarity anti-reverse structure.

OVERCURRENT PROTECTOR

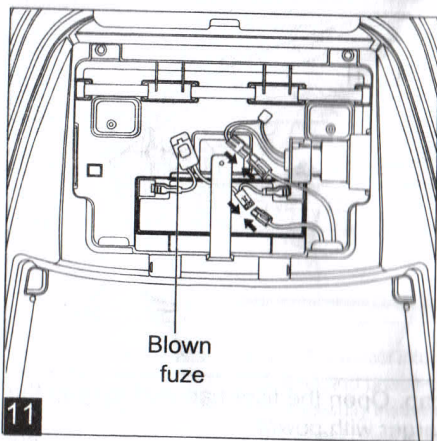

- Overcurrent protector is installed under the seat.
- Motherboard is equipped with automatic recovery fuse. When it is overloaded or improper used, disabling the motor, the fuse will automatically disconnect the power. To reset, just turn off the key switch and wait 30 seconds, the fuse will automatically recovered.
- Power device is equipped with blown fuze. When short-circuit happens, the fuze will be blown. Therefore, after solve the circuit problem, you need to replace the blown fuze.

OPERATING FUNCTION

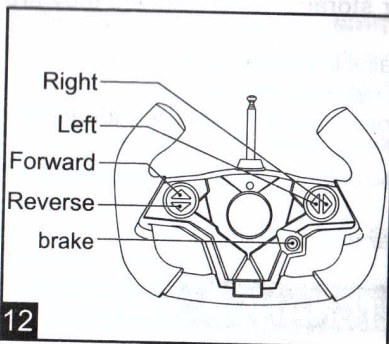

1. Transmitter

- Transmitting signal can cover about 20-30meters across. If transmitter does not perform properly within this coverage, please check its battery.
- Before using the remote control, you need to open the main power, and then open the remote control power. After matching the remote control and the car successfully, it can be used.

Remark: in order to protect the motor, the power of left/right button on the transmitter will be cut off if you press left/right button for over 2 seconds. Therefore, a continuous turning will require you to press left/right button repeatedly.

2. Steering wheel

- Switch: switch of controlling horn
- Horn: Horn sound can be activated when press.

CAUTION!
RISK OF FIRE. Do not bypass. Replace only with 250V 20A.

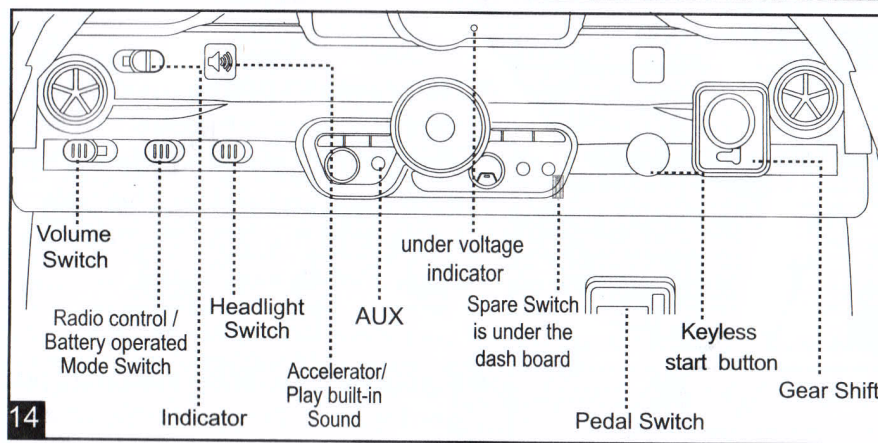
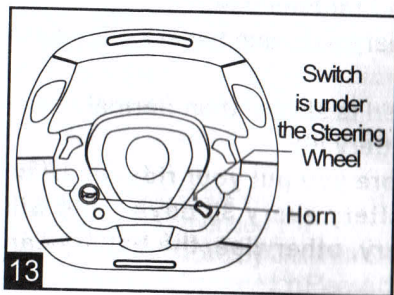

Ride-on Function

Press the Start button to start the vehicle.

Forward at high speed: put the Gear Switch in D2 gear and step on pedal switch, the ride-on will move forward at high speed.

Forward at low speed: put the Gear Switch in D1 gear and step on pedal switch, the ride-on will move forward at low speed.

Stop: put the Gear Switch in STOP gear, the ride-on will stop moving.

Reverse: put the Gear Switch in R gear and step on pedal switch, the ride-on will move backward.

Left: steer left the steering wheel when ride-on is moving forward.

Right: steer right the steering wheel when ride-on is moving forward.

under voltage indicator: After 80% of battery capacity had been consumed, the indicator will be light. If continued to use, the power will be automatically shut off. Need to be full charged.

If indicator light is on, which means the battery is of low voltage, the ride-on won't work. Only when indicator light is out, which means battery is fully charged, can ride-on work.

There is a spare switch underneath the dashboard. This switch is functionally equivalent to the keyless start button, switch upward is off and downward is open. Please note that when the keyless start button OR spare switch opens, the function of car is opened. Only when two switches are both off, the function of car can be turned off.

Radio control /Battery operated Mode Switch

The pedal switch, gear shift will be inactive when you switch to Remote Control Mode. To avoid scaring the child while ride-on starts to run forward/reverse, the remote control operation is equipped with low speed start function.

NOTICE!

When not playing AUX, please pull the AUX Input Wire out of AUX socket. Otherwise, all other sound effect will be mute.

ON/OFF function

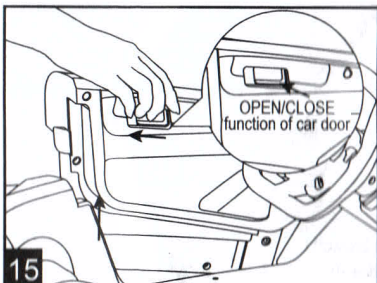

- Red (yellow) button inside is for OPEN/CLOSE function of car door. When pushing the button backward and pulling the button upward to the top, the door will open (Please see Picture 15).

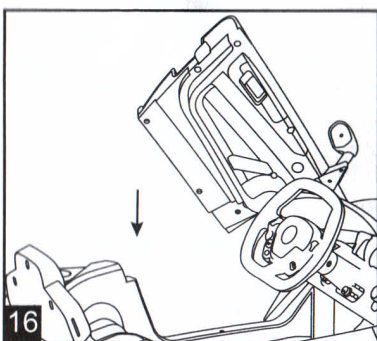

- If you want to close the door, pls gently push the door downward, when you hear the click sound and cannot not pushing/pulling the button at the same time, that the door is closed(Please see Picture 16).

MAIN BOARD REPLACEMENT

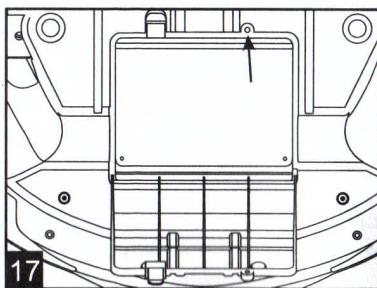

- The cover plate at the front bottom of the car is designed for changing mainboard, loudspeaker or other accessories. When the accessories need to be changed, just unscrew the screw and open the cover plate, then you can see the mainboard cover(Please see Picture 17)

WARNING

Please read carefully since it contains important information.

- Children are not allowed to operate charging. It should be operated by adult.
- Ride-on operation should be under adults' supervision.
- This product should be assembled by adult; or checked by adult to make sure proper assembly.
- It is prohibited to run this ride-on in public streets, roads, slope, near swimming pool, or any other dangerous area.

- This ride-on can not be overloaded. The maximum loading capacity is 25 kilograms.
- This ride-on is for children age between 37months old - 96months old.
- Some accessories of ride-on may be damaged by improper operation.
- Do not suddenly use forward-reverse switch during running. It can only be used when the ride-on is stopped.
- Swab ride-on with cloth. Do not flush the ride-on with water in case damage.
- Charger is not considered as toy. Please put it away after charging.
- This product is made of plastics. Please keep it away from fire.
- Re-start of the motor may occur sparkles. It is prohibited to run in flammable and explosive area such as gas station.
- Do not let children touch wheels in case being trapped or crushed. Please keep other children away from the ride-on during running.
- Flat ground is good for ride-on running. Please avoid running on sand or any other rough ground.
- The package of ride-on is not toy for children.
- Adults are required to read this instruction carefully and give correct guideline to children before playing.
- This seat belt is only a decoration to develop the safety sense of children, it can not provide any substantial protection.
- Please guide children how to start and relax the pedal, how to handle malfunctions and how to stop ride-on.
- Do not use the malfunctioning ride-on until it is well repaired.
- The antenna and wire are not to be inserted into socket-outlets.

CAUTION!

You may find battery damage, liquid leakage and other dangerous phenomenon during replacement. Please pay attention to the following:

- One 9V battery is needed for this ride-on.
- Battery replacement should be operated by adults.
- Install batteries correctly according to their polarity .
- Storage battery can be removed from the ride-on and recharged, but can NOT be heated or disposed of in fire.
- Non-rechargeable batteries are not to be recharged. Rechargeable batteries can be recharged under adults' supervision; Rechargeable batteries are to be taken out from ride-on during charging.
- When batteries are short of power, the remote control distance will be shorten. Please replace with new batteries.
- Take out batteries if ride-on is not in use for an extended period in case liquid leakage. Remove batteries when they are used up.
- Supply terminals are not to be short-circuit.
- This ride-on is not for children under 36 months since it may have small parts that can detach during running.
- Transmitter can only be operated by adults or under adults' supervision.

CARE AND MAINTENANCE

- Please do not play until it is fixed perfectly if there is any damaged.
- Please check and maintain the car in regular time for keeping your child safe.

- Please periodically check and make sure there are no screws loosening and spare parts damaged.
- Before installing and using the car, please check all spare parts carefully.
- For avoiding unnecessary damages, please read this instruction in detail before assembly and disassembly.

MALFUNCTION SHOOTING GUIDE

Malfunction	Analysis	Solution
Car is not running	<ul style="list-style-type: none"> ● Storage battery connectors are not well connected ● Gear shift is in the wrong place ● Car is over-loaded ● Main body circuit is damaged 	<ul style="list-style-type: none"> ● Reconnect ● Gear shift should be in the forward or backward position ● Reduce loaded weight to under 25KGS ● Please ask after-sale service for help
Car runs in low speed	<ul style="list-style-type: none"> ● Storage battery power is low ● Ground is uneven 	<ul style="list-style-type: none"> ● Fully charge battery ● Choose an even place
Battery cannot be charged	<ul style="list-style-type: none"> ● Battery connectors are not well connected ● Charger is not charged with electricity ● Charger is broken 	<ul style="list-style-type: none"> ● Reconnect ● Reconnect ● Replace charger
Car cannot stop	<ul style="list-style-type: none"> ● Car is damaged 	<ul style="list-style-type: none"> ● Please ask after-sale service for help
Continue range is short	<ul style="list-style-type: none"> ● Battery is not fully charged ● Battery is over used 	<ul style="list-style-type: none"> ● Re-charge ● Replace battery
Faint sound and heat occurs when charging battery	<ul style="list-style-type: none"> ● Chemical reaction 	<ul style="list-style-type: none"> ● Normal reaction
Gear box is noisy	<ul style="list-style-type: none"> ● Gear is broken 	<ul style="list-style-type: none"> ● Please ask after-sale service for help
Power led is off	<ul style="list-style-type: none"> ● Car power switch is off ● Battery is power-off 	<ul style="list-style-type: none"> ● Turn on the power switch ● Charge the battery
Charger led is off	<ul style="list-style-type: none"> ● Charger is broken 	<ul style="list-style-type: none"> ● Please ask after-sale service for help

RIDE-ON ELETRICAL ILLUSTRATION (Transmitter-operated / Pedal-operated)

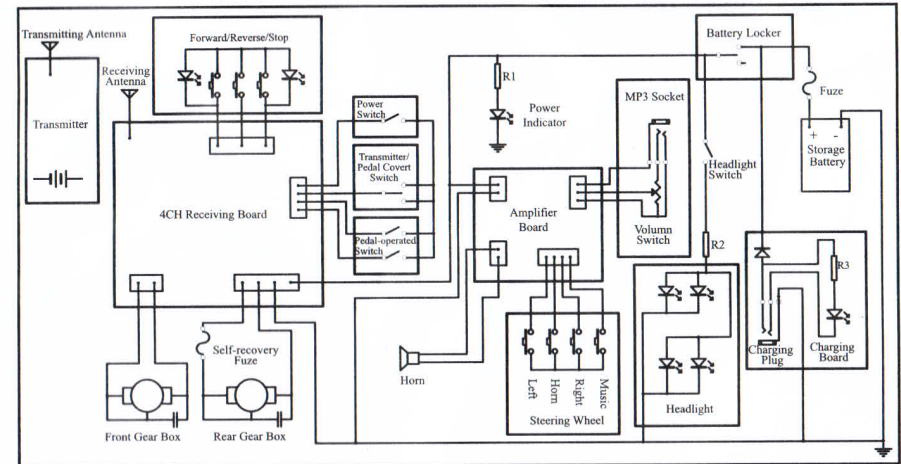

Remark: Specification may vary from this electrical illustration.

MAINTENANCE

- This product comes with maintenance service.
- Maintenance fee is required for product malfunction caused by improper operation or man-made factor, or if it has exceeded guarantee.
- Maintenance service can be provided by the seller andus. Invoice, maintenance record and malfunctioning product/part(s) will be required.

MAINTENANCE RECORD

Date	Details	Result	Remark

Customer Name: _____

Tel: _____

Address: _____

Item NO.: _____

Invoice NO.: _____



RASTAR GROUP

Produced under license of Ferrari S.p.A. The name FERRARI, the PRANCING HORSE device, all associated logos and distinctive designs are property of Ferrari S.p.A. The body designs of the Ferrari cars are protected as Ferrari S.p.A. property under design, trademark and trade dress regulations.

Licensee: RASTAR (HK) INDUSTRIAL COMPANY LIMITED

Manufacturer: XINGHUI BABY SUPPLIES CO.,LTD.

Add : North Area, Zhaoan Industrial Park, Zhangzhou, Fujian, China.

20160723

08.06.827000.000260